

PIVOT  
MECHANISM  
SYSTEM

PANIDIS   
MAKEDONIKI • ALUMINIUM SYSTEM COMPONENTS

MPH-150      \\Installation on Threshold  
MPH-150-S    \\Installation on the Floor

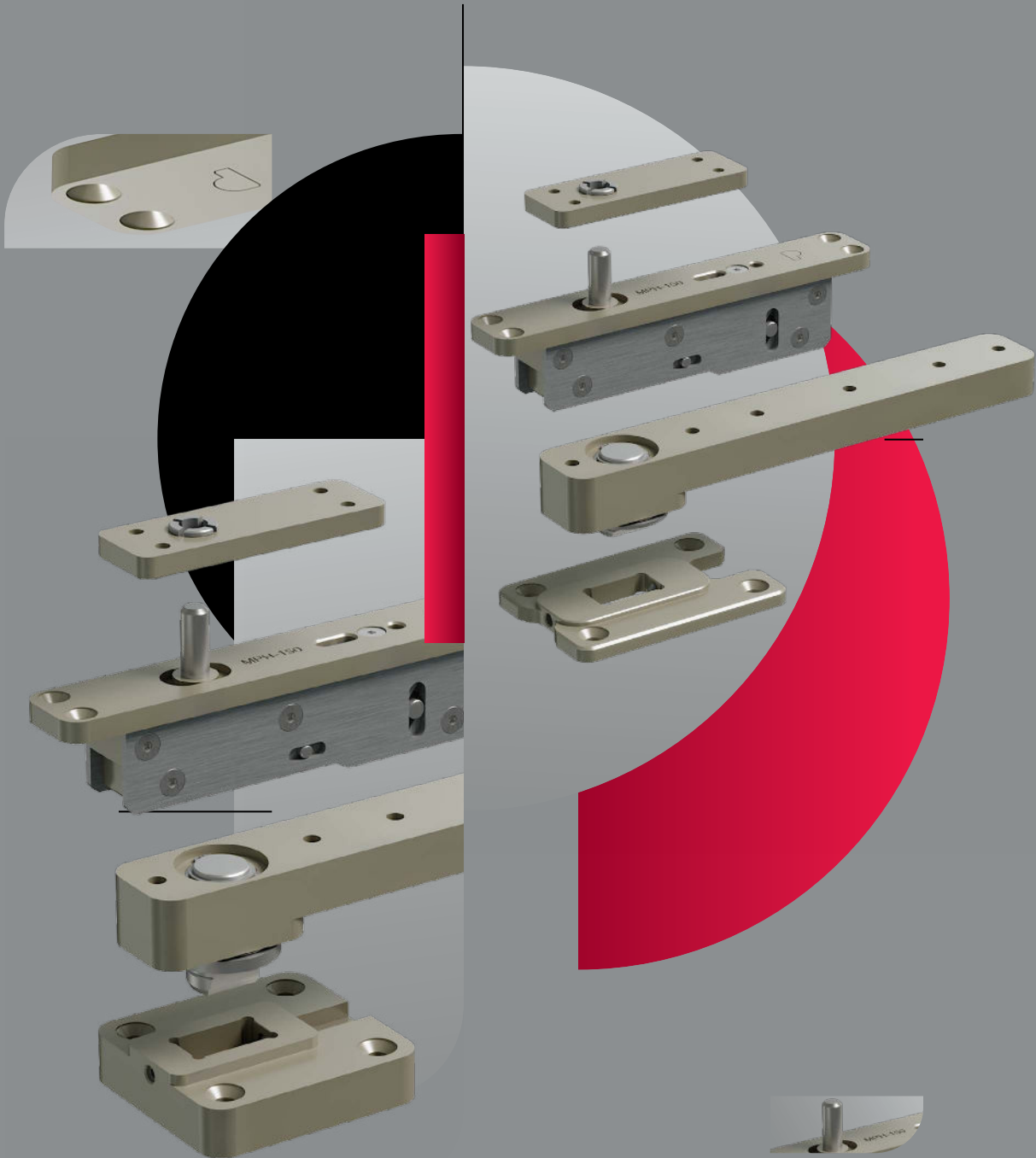

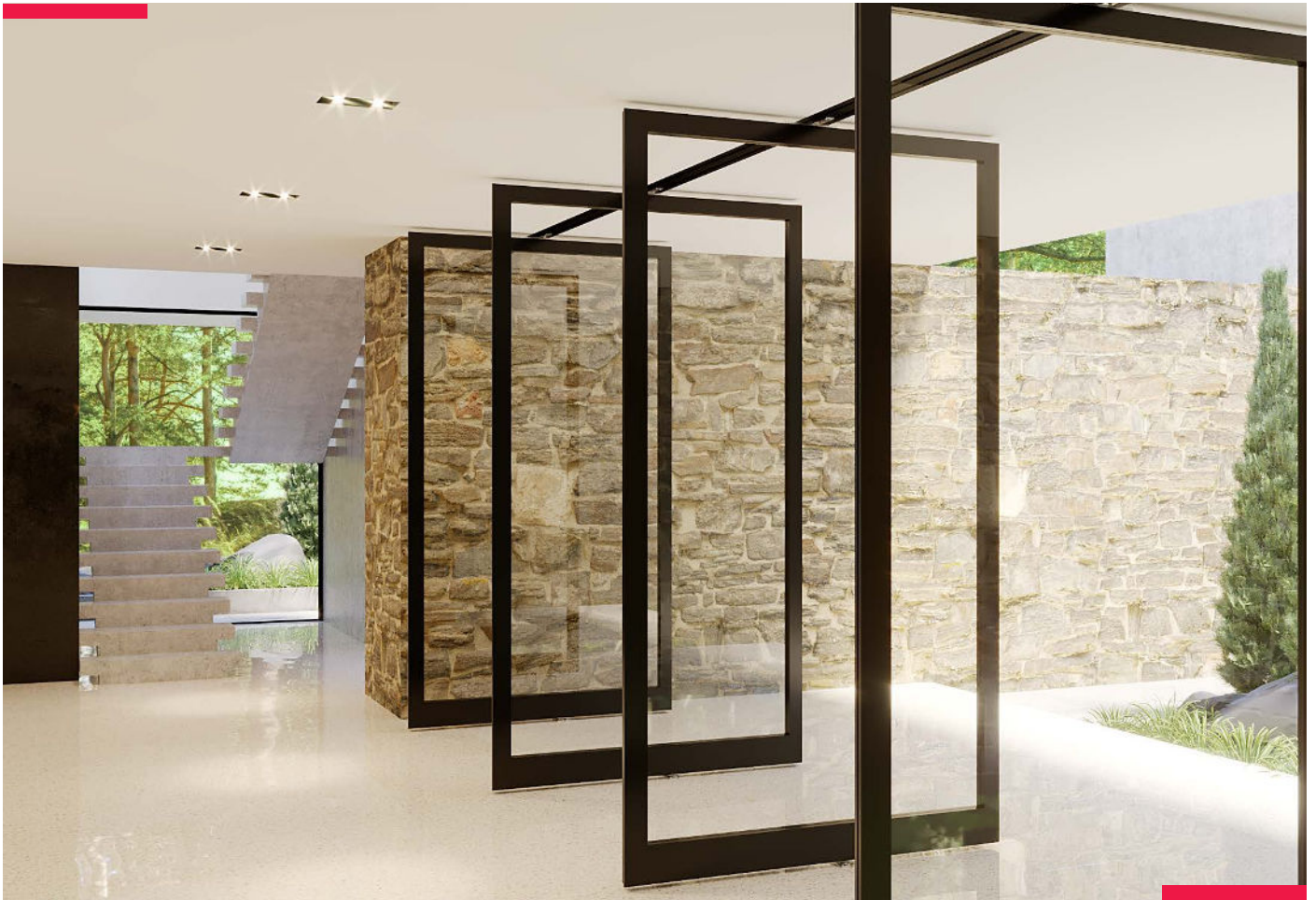

## **MPH-150 , MPH-150-S**

PIVOT MECHANISM SYSTEM FOR INSTALLATION:  
A)ON THRESHOLD , B)ON THE FLOOR

Leveraging its exceptional know-how and productive capacity, **PANIDIS S.A.** designed the advanced **MPH-150 , MPH-150-S** mechanism system.

The smart and innovative design of the system allows it to be fitted on large internal and external doors of different shapes and materials, such as aluminium, iron, wood or glass (with frame), offering endless options in terms of architectural design.

The **PIVOT MPH-150 , MPH-150-S** mechanism system is manufactured of stainless steel and specially treated anodised aluminium, namely materials that ensure excellent operation reliability with zero maintenance needs while being super resilient even in extreme environmental conditions.



## MPH-150

### PIVOT MECHANISM SYSTEM FOR INSTALLATION ON THRESHOLD

#### Technical specifications:

- Load capacity up to 250 kg.
- Door thickness from 40mm to 90mm.
- Easy to install & zero maintenance requirements.
- Installation on the bottom side (door threshold) with the pre-installation of M6 female rivets on it.
- Easy to adjust when the door is installed.
- **±5mm horizontal adjustment (top side).**
- **±3mm adjustment (bottom side).**
- Opens both ways (right-left) with a 360° motion range.
- **Door can be delivered pre-assembled on site.**
- Suitable for large doors, made of steel, wood, aluminium or glass (with frame).
- No special infrastructure on floor and ceiling required.
- For external or internal doors with single or double installations.
- For residential or business use.
- The system consist from 2 subparts: upper subpart (MPH-152) & bottom subpart (MPH-151)



## MPH-150-S

### PIVOT MECHANISM SYSTEM FOR INSTALLATION ON THRESHOLD

#### Technical specifications:

- Load capacity up to 250 kg.
- Door thickness from 40mm to 90mm.
- Easy to install & zero maintenance requirements.
- Installation directly on the floor.
- Easy to adjust when the door is installed.
- **±5mm horizontal adjustment (top side).**
- **±3mm adjustment (bottom side).**
- Opens both ways (right-left) with a 360° motion range.
- **Door can be delivered pre-assembled on site.**
- Suitable for large doors, made of steel, wood, aluminium or glass (with frame).
- No special infrastructure on floor and ceiling required.
- For external or internal doors with single or double installations.
- For residential or business use.
- The system consist from 2 subparts: upper subpart (MPH-152) & bottom subpart (MPH-151S)

## INSTALLATION PREVIEW OF THE PIVOT MECHANISM SYSTEM **MPH-150**



**MPH-152** Installation of the mechanism on the sash or frame.  
(illustrated part MPH-152-A & MPH-152-B)



**MPH-151** Installation of the mechanism on threshold.  
(illustrated part MPH-151-A & MPH-151-B)

## INSTALLATION PREVIEW OF THE PIVOT MECHANISM SYSTEM **MPH-150-S**



**MPH-152** Installation of the mechanism on the sash or frame.  
(illustrated part MPH-152-A & MPH-152-B)



**MPH-151-S** Installation of the mechanism on threshold.  
(illustrated part MPH-151-A & MPH-151S-B)

# **INSTALLATION INSTRUCTIONS**

## **PIVOT MECHANISM SYSTEM**

### **MPH-150 / MPH-150-S**

#### **MECHANISM SUBPARTS:**

##### A) Parts of PIVOT Mechanism System MPH-150:

- MPH-151-A (bottom part / arm / installation into the sash)
- MPH-151-B (bottom part / plate / installation on threshold)
- MPH-152-A (upper part / mechanism / installation into the sash-frame)
- MPH-152-B (upper part / plate / installation into the sash-frame)

##### B) Parts of PIVOT Mechanism System MPH-150-S:

- MPH-151-A (bottom part / arm / installation into the sash)
- MPH-151-B (bottom part / plate / installation on the floor)
- MPH-152-A (upper part / mechanism / installation into the sash-frame)
- MPH-152S-B (upper part / plate / installation into the sash-frame)

\*This coding refers only to this handbook for convenience during the installation.

**Step 1 - Installation of the mechanism MPH-152-A (mechanism)**

**Instructions:**

Calculate and create a notch on the top of the sash and install the MPH-152-A into the sash.

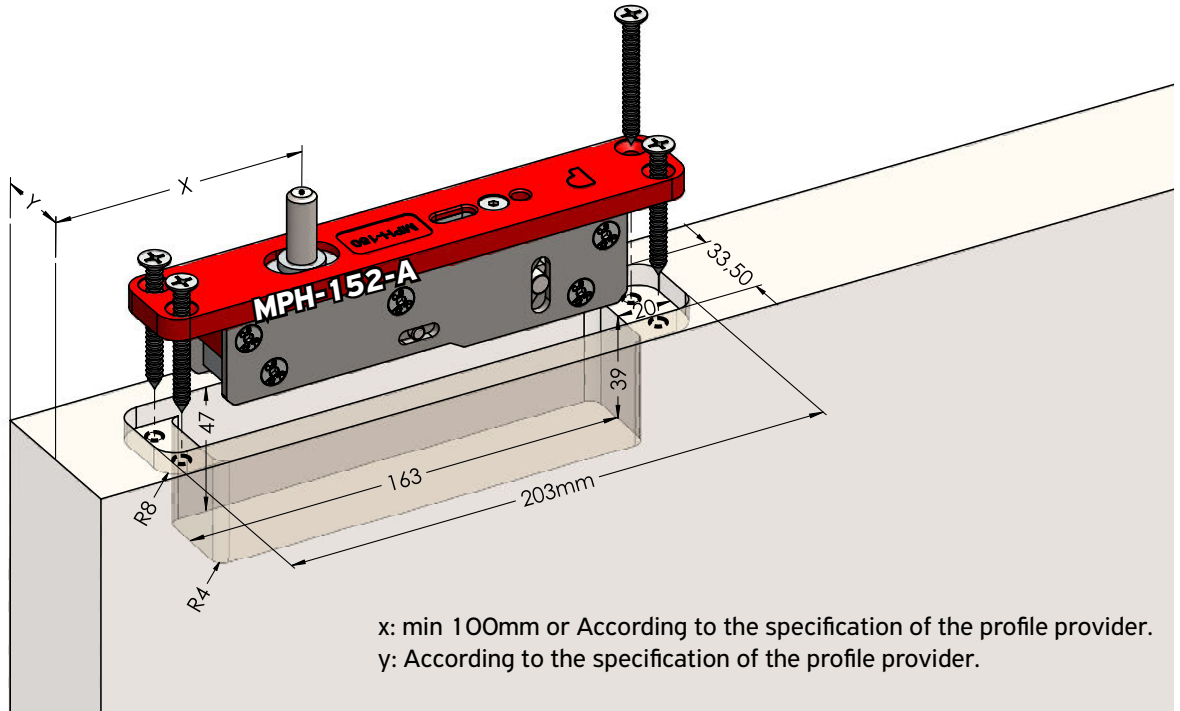

8

**Alternative installation - Installation of the MPH-152-A (mechanism)**

Calculate and create a notch on the top of the frame and screw the MPH-152-A into the door frame.

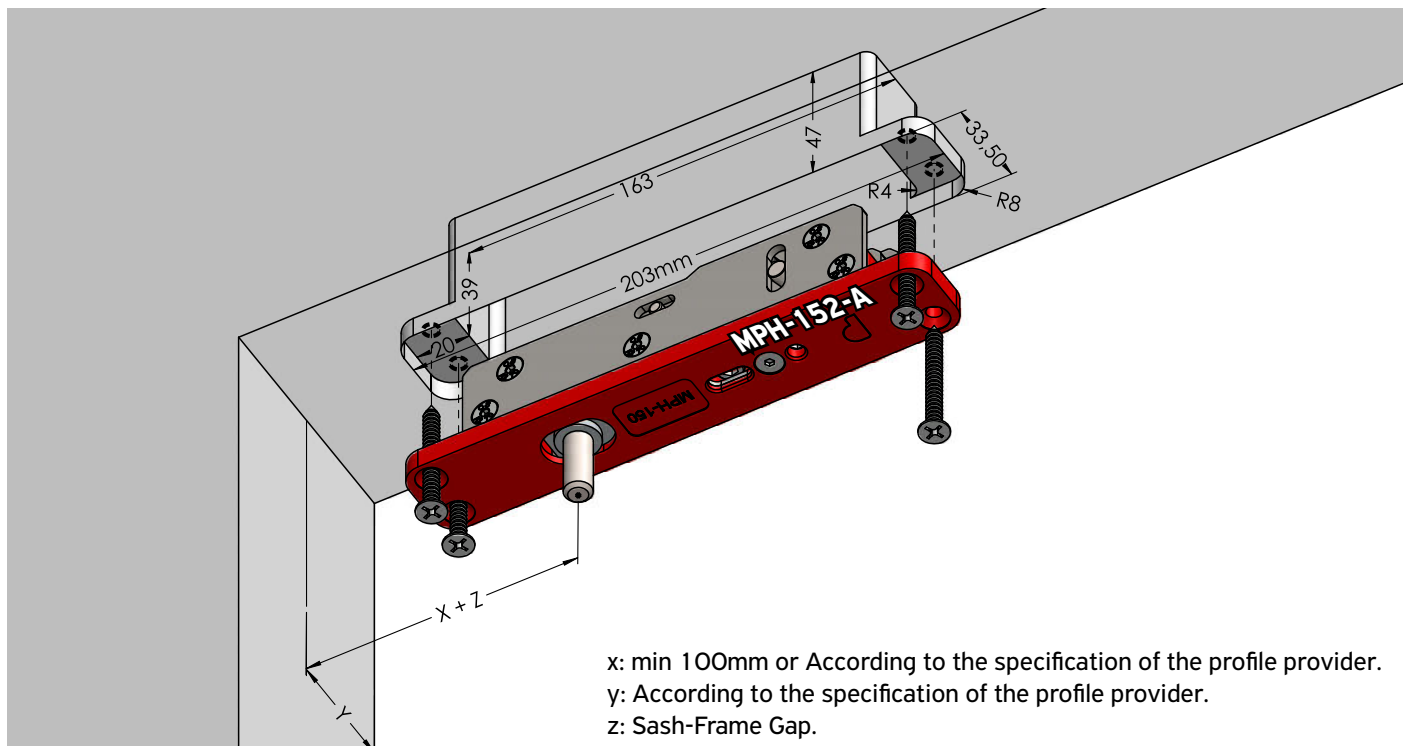

**Step 2 - Mounting of the top plate: MPH-152-B (upper plate)**

**Instructions:**

Calculate and create a notch on the top of the frame and install the MPH-152-B.

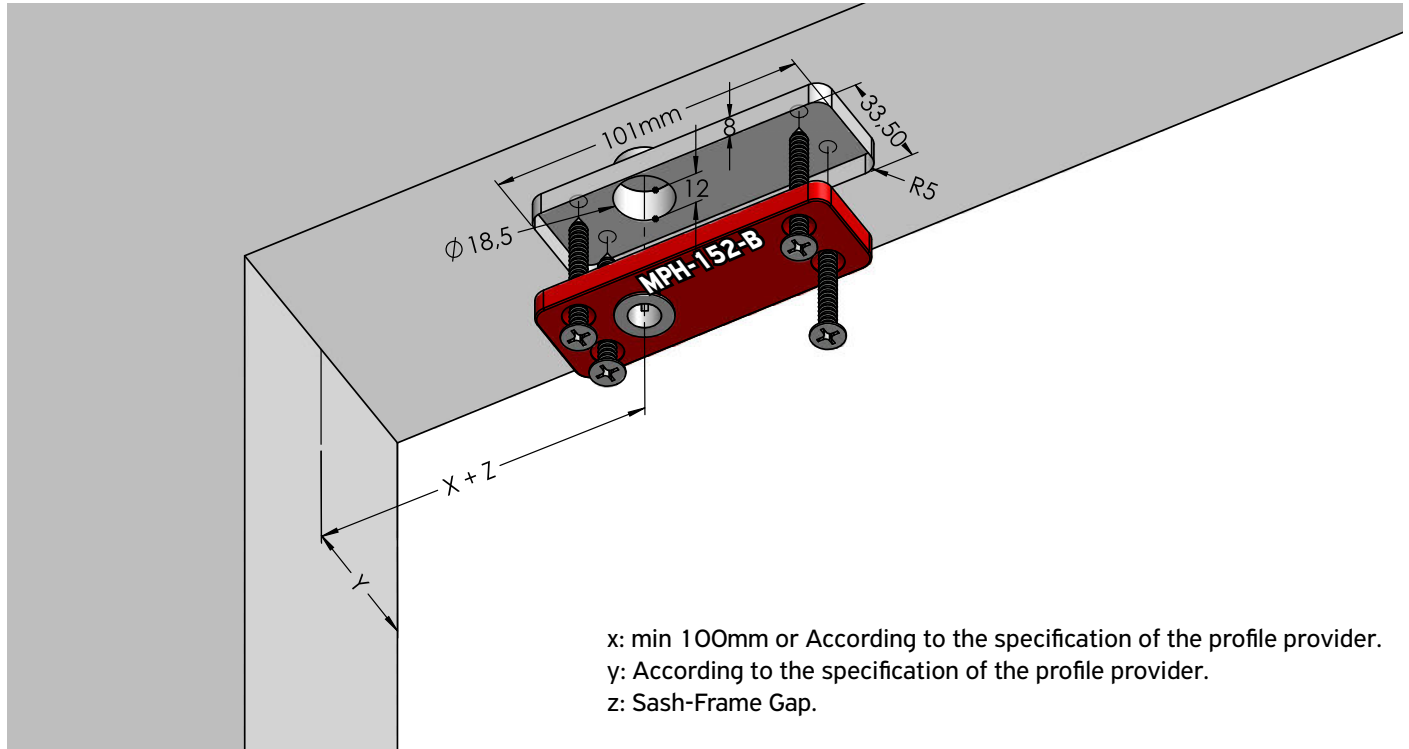

**Alternative installation - Installation of the MPH-152-B (upper plate)**

Calculate and create a notch on the top of the sash and install the MPH-152-B into the sash.

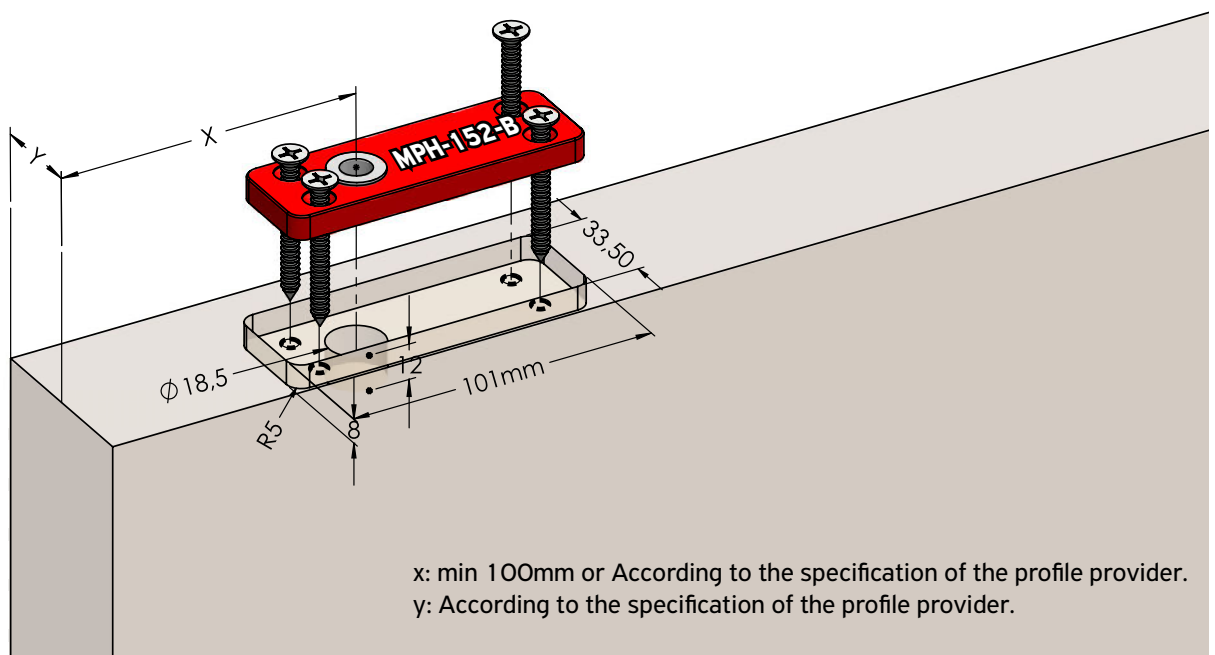

**Step 3 - Installation of the part:**

**a) MPH-151-B on Threshold , b) MPH-151S-B on the floor**

**Instructions:**

**a) MPH-151-B**

Calculate and create a notch on threshold and install the MPH-151-B, by either using pressure nuts or not.

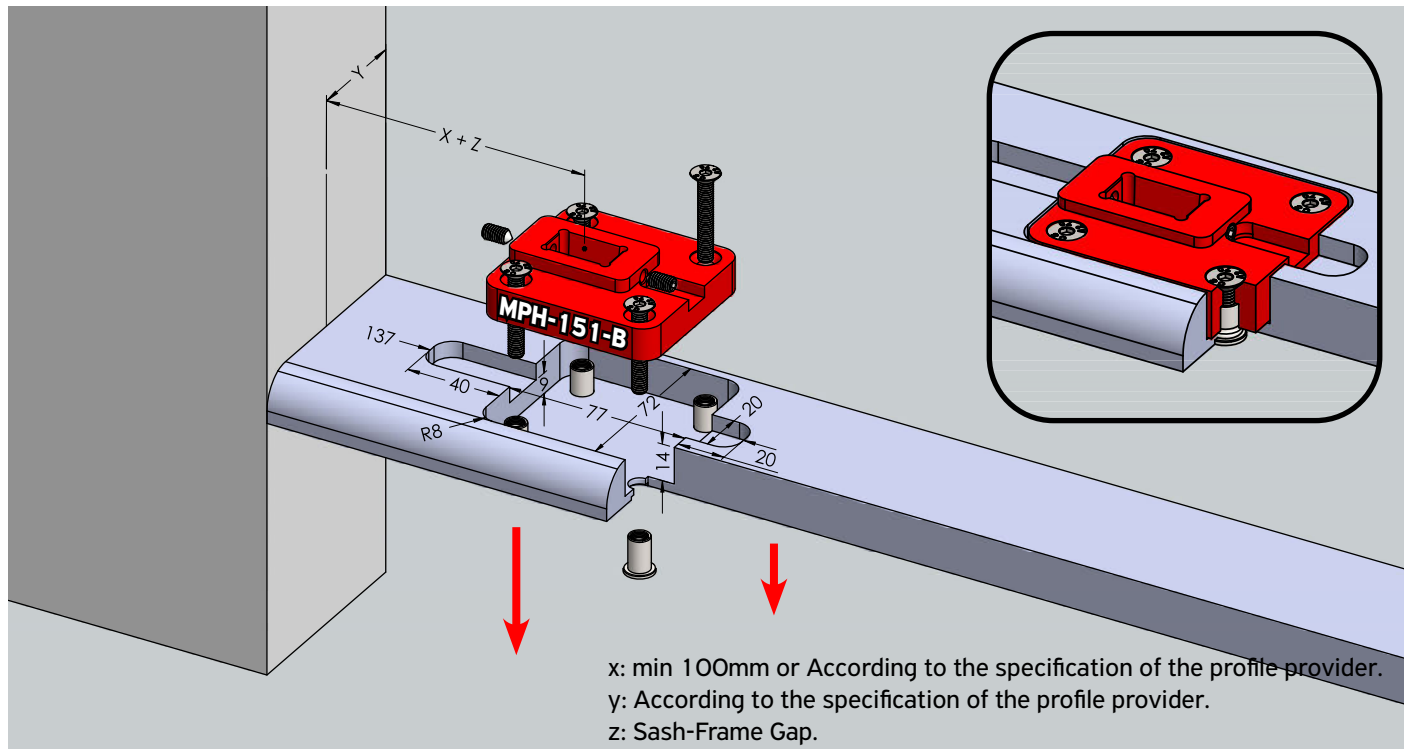

**b) MPH-151S-B**

Calculate and install the MPH-151S-B on the floor.

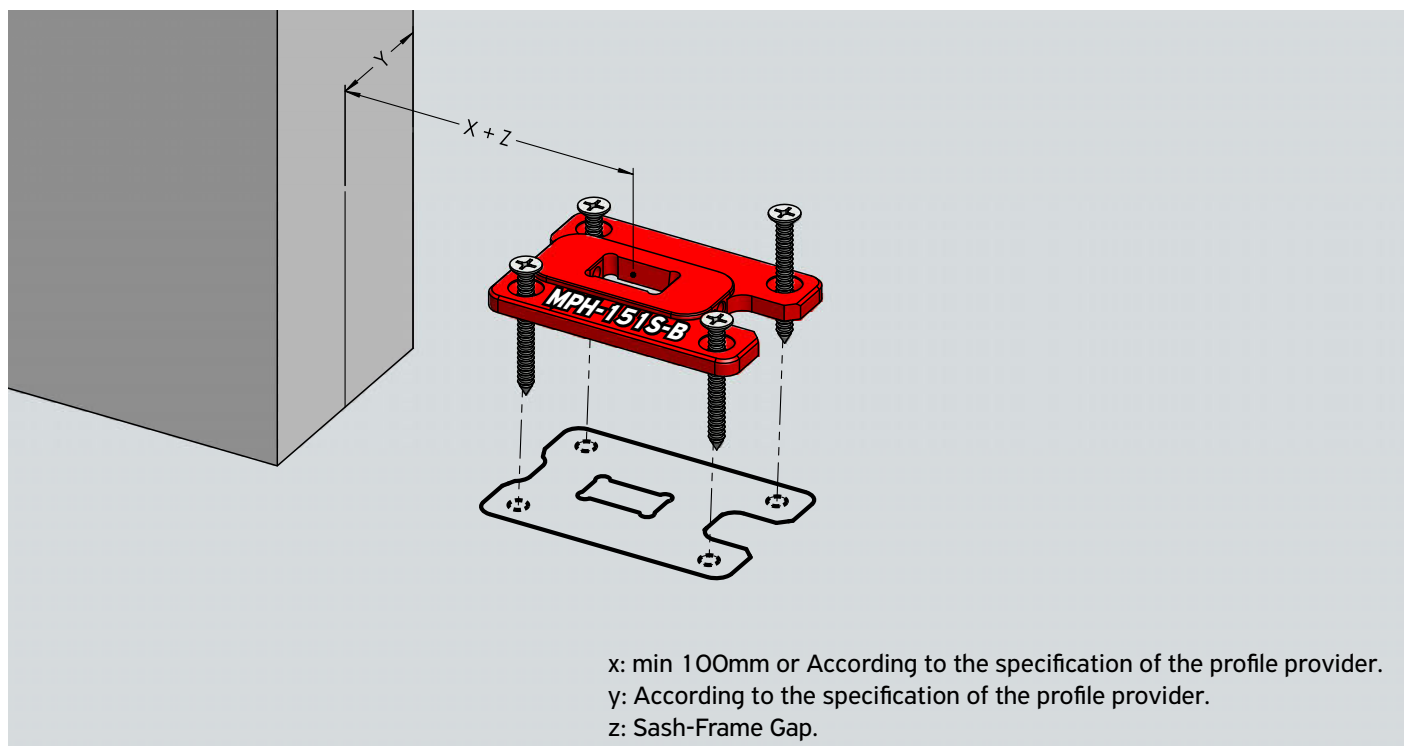

**Step 4 - Installation of the part: MPH151-A (arm)**

**Instructions:**

Calculate and create a notch on the bottom of the sash and install the MPH-151-A. The pin must be aligned on a virtual vertical axis with the pin of upper part of the door.

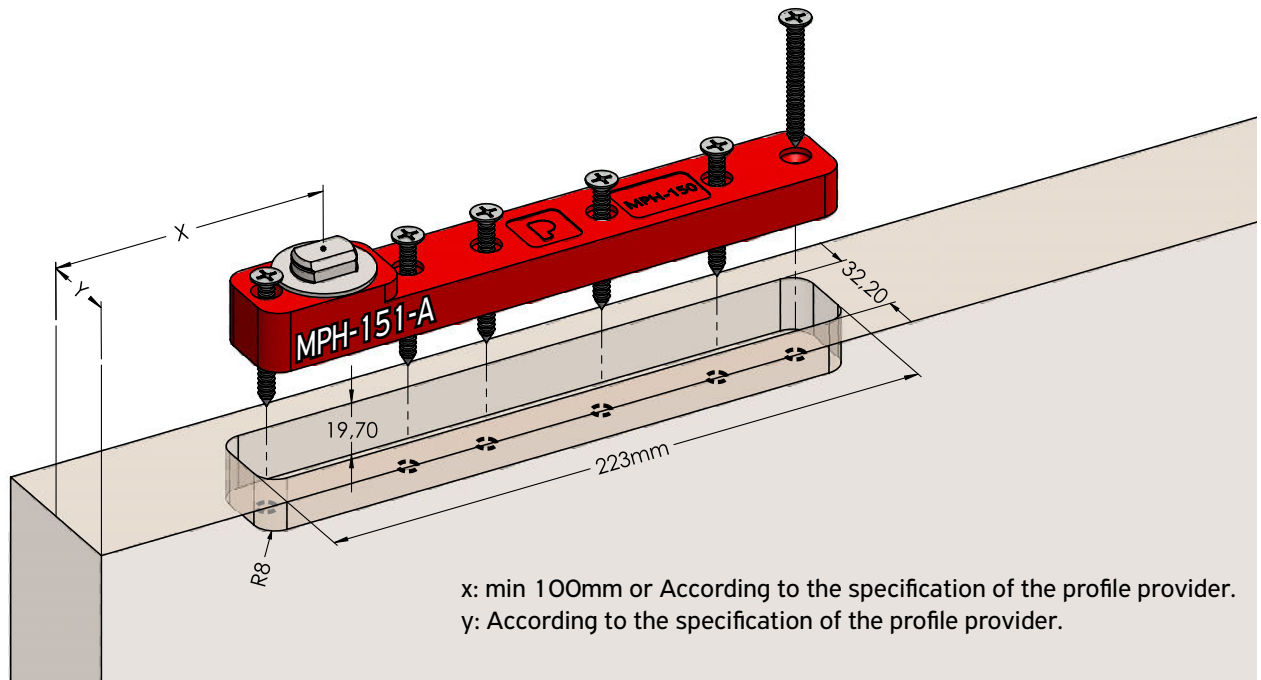

**Step 5 - Installing the door:**  
**a) On threshold, b) On the floor**

**Instructions:**

**a)** Bring the door to lateral position, as shown below, and install the door on the bottom plate

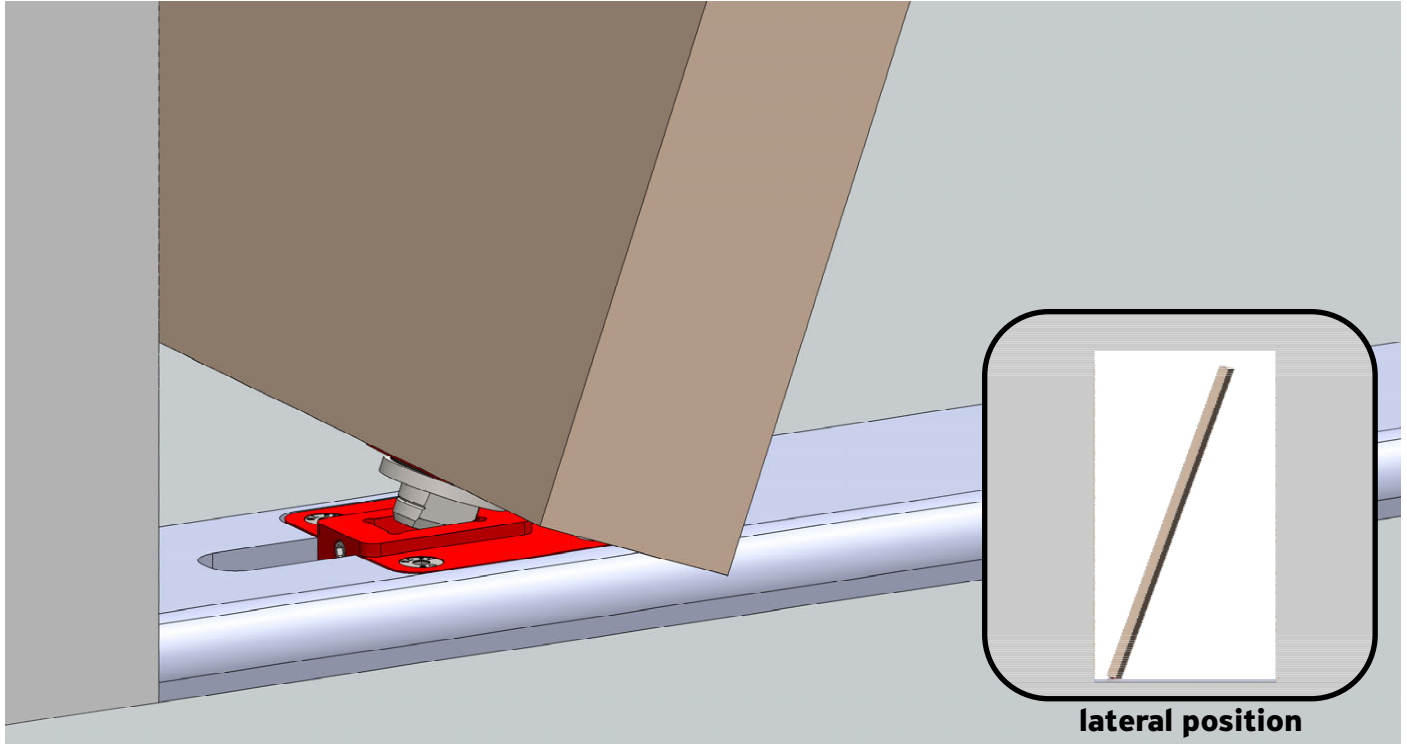

**b)** Bring the door to lateral position, as shown below and install the door on the bottom plate

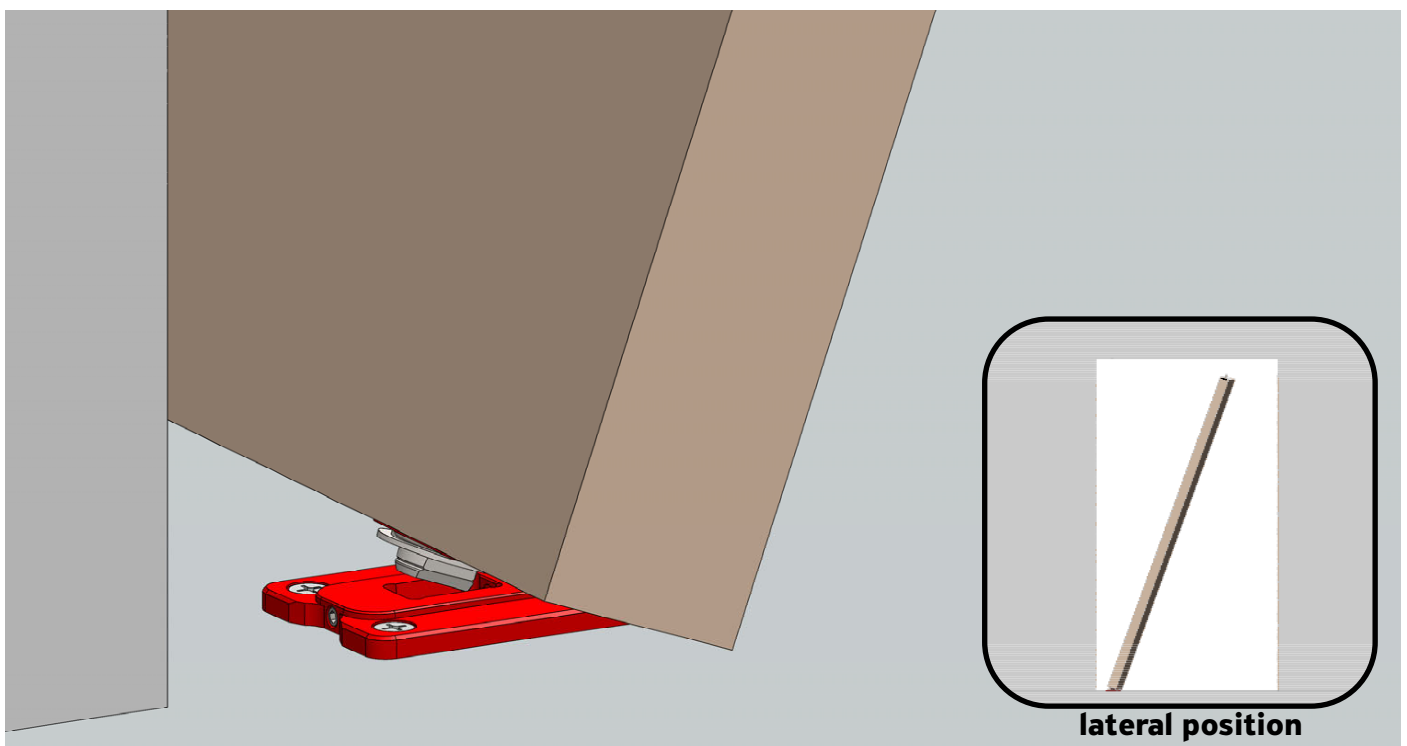

**Step 6: Installing the door:**

**a) Pin extrusion, b) Horizontal position adjustment**

**Instructions:**

**a)** Hold the door in vertical position and start to extrude the pin as shown below. Carefully extrude the pin entirely.

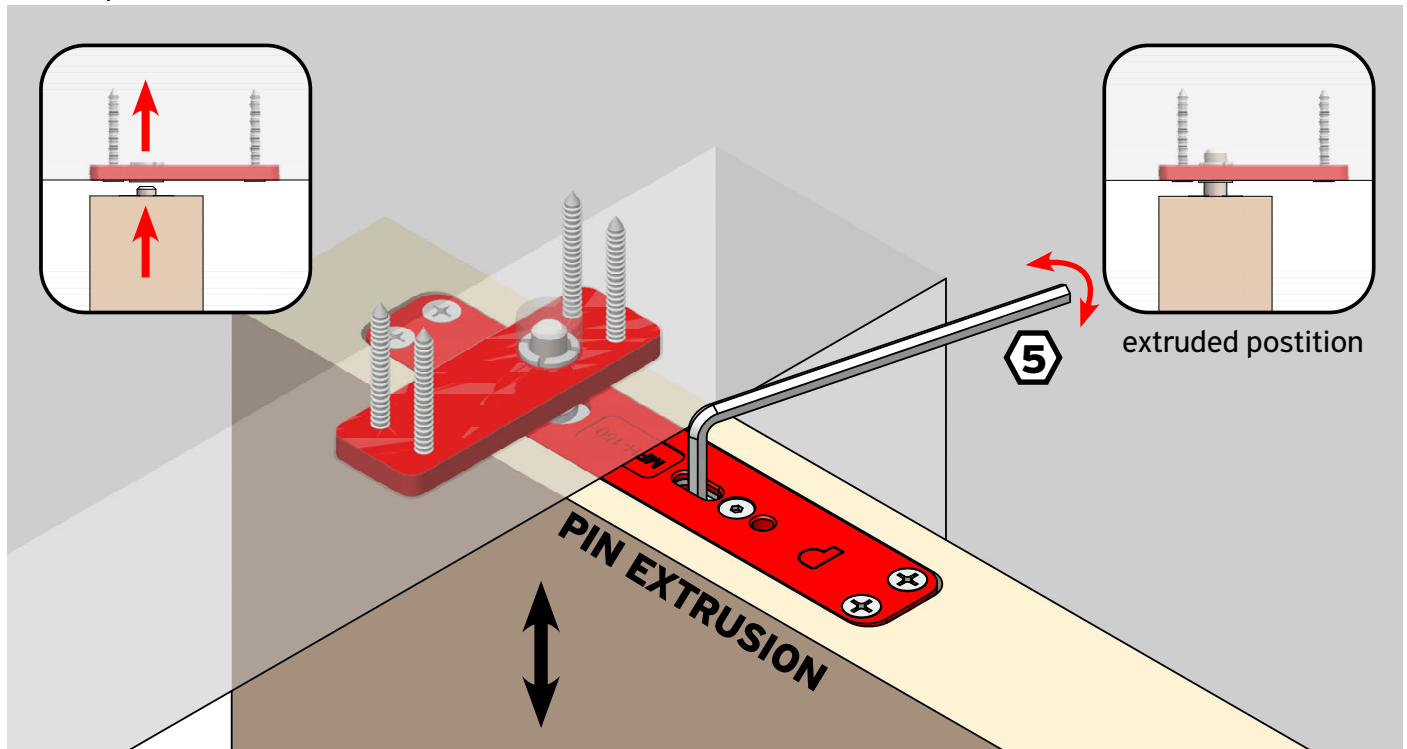

13

**b)** Tighten-untighten the grabbing-adjusting screws to adjust the horizontal position of the door and then fasten tightly.

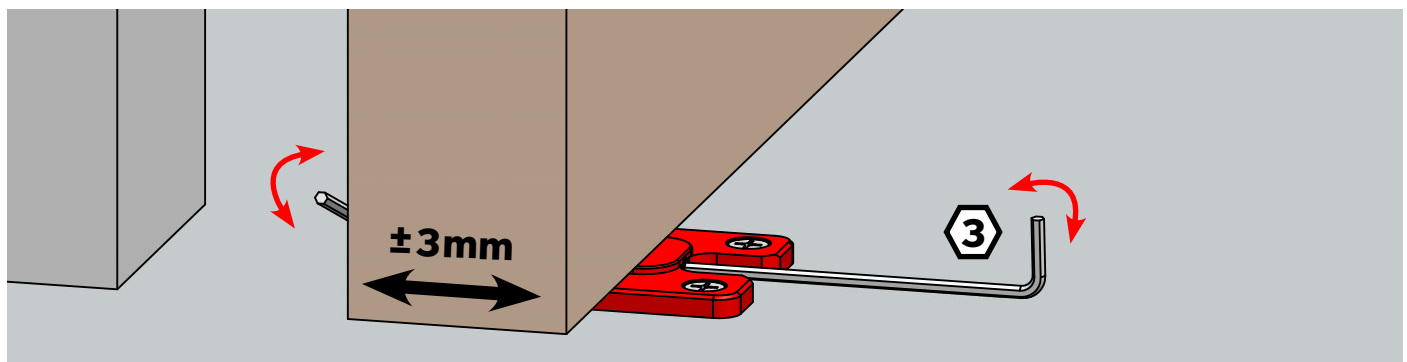
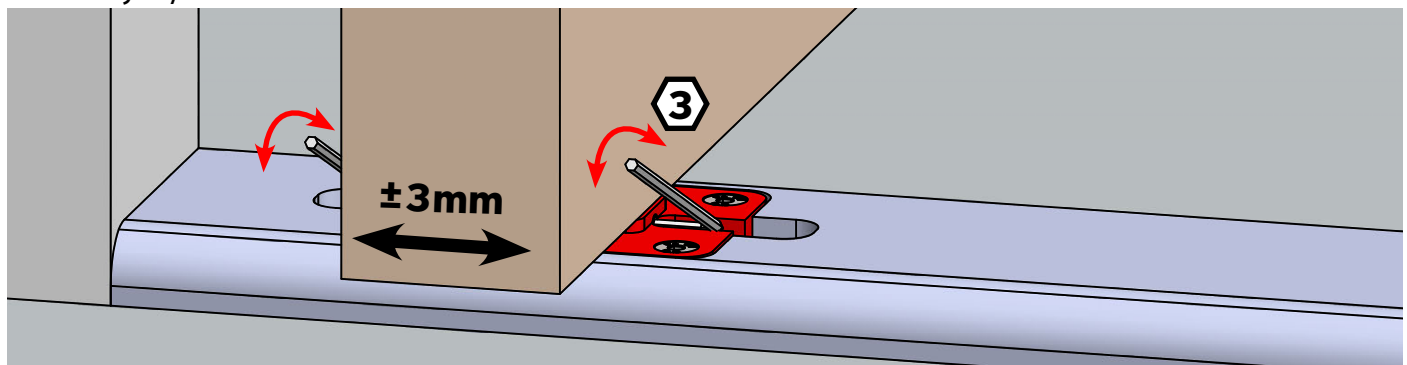

**Step 7 - Installing the door:**

**a) Horizontal adjustment of the pin, b) Lock the mechanism**

**Instructions:**

**a) Carefully adjust the horizontal position of the pin.**

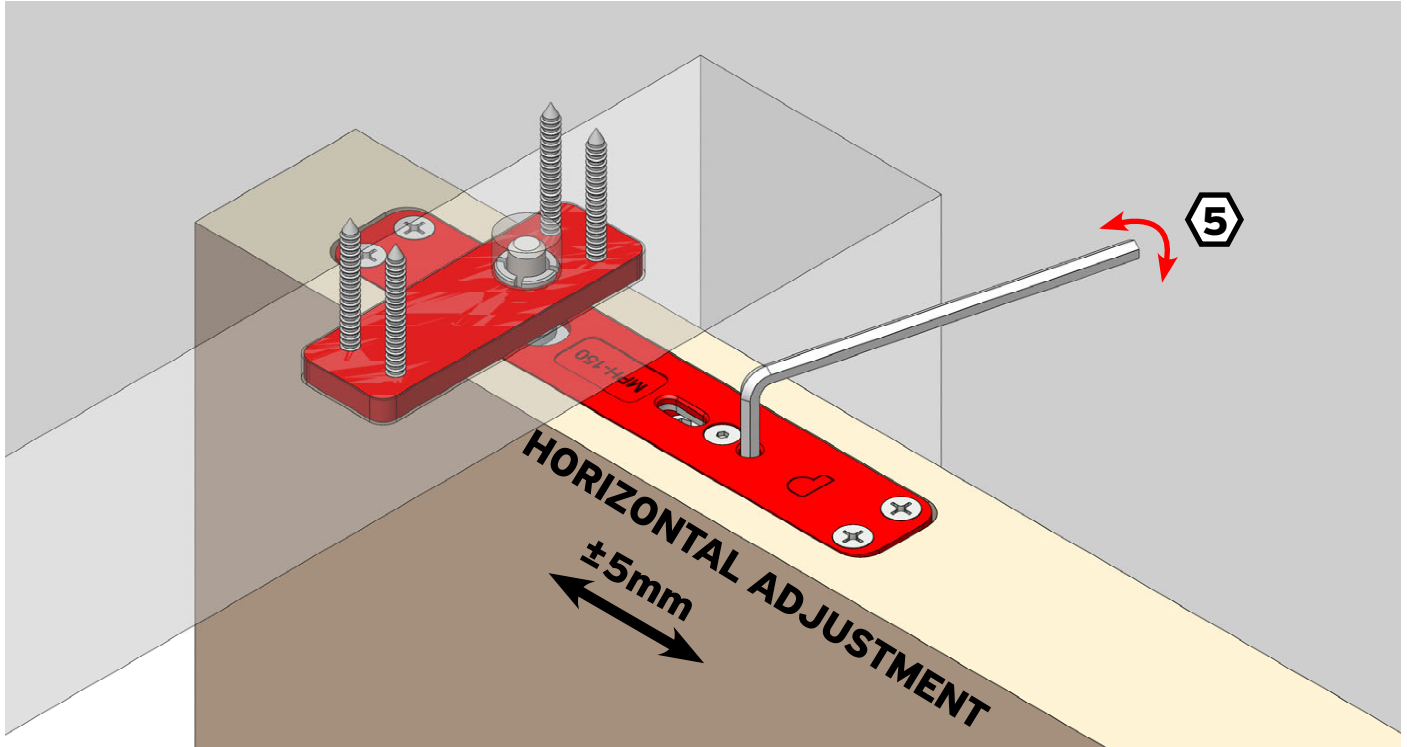

**b) Tighten the screw that locks in position the pin of the mechanism.**

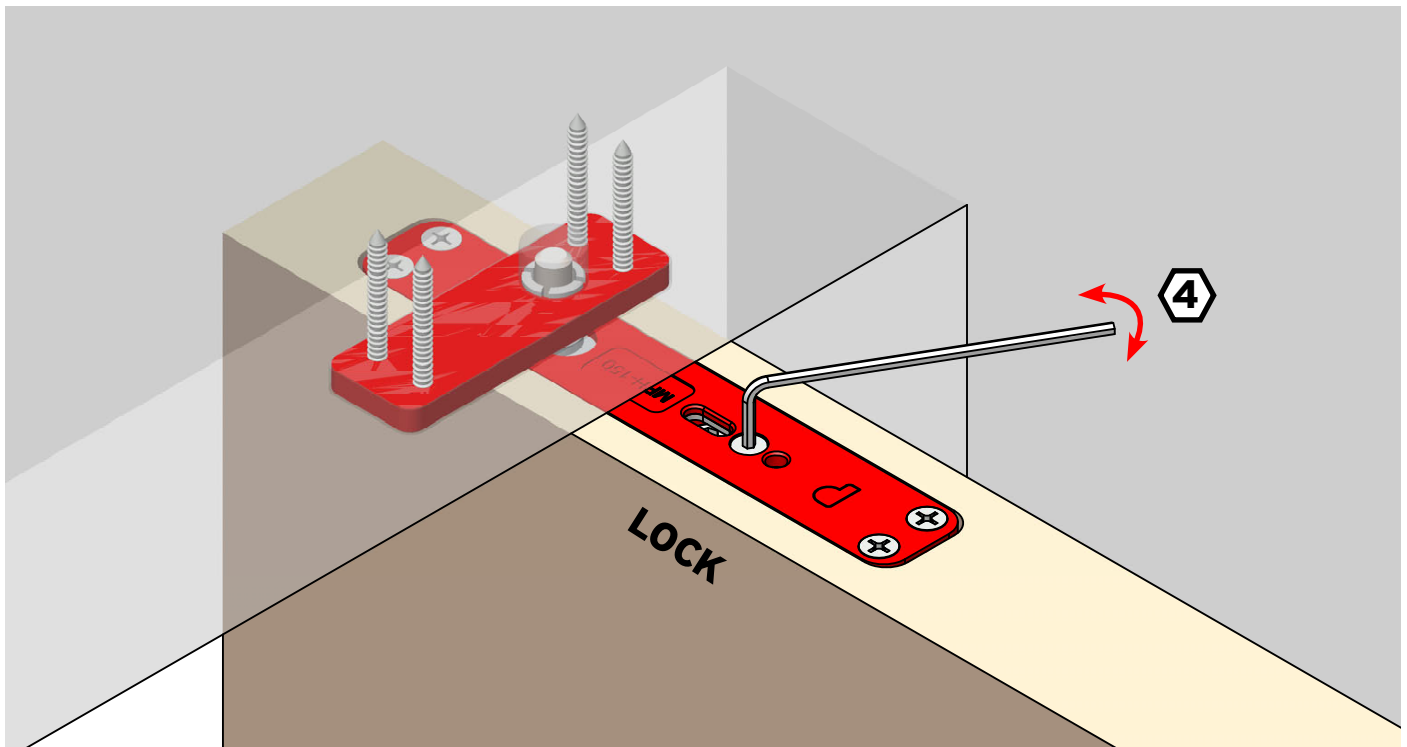

### HINGE PIVOT - MPH-150

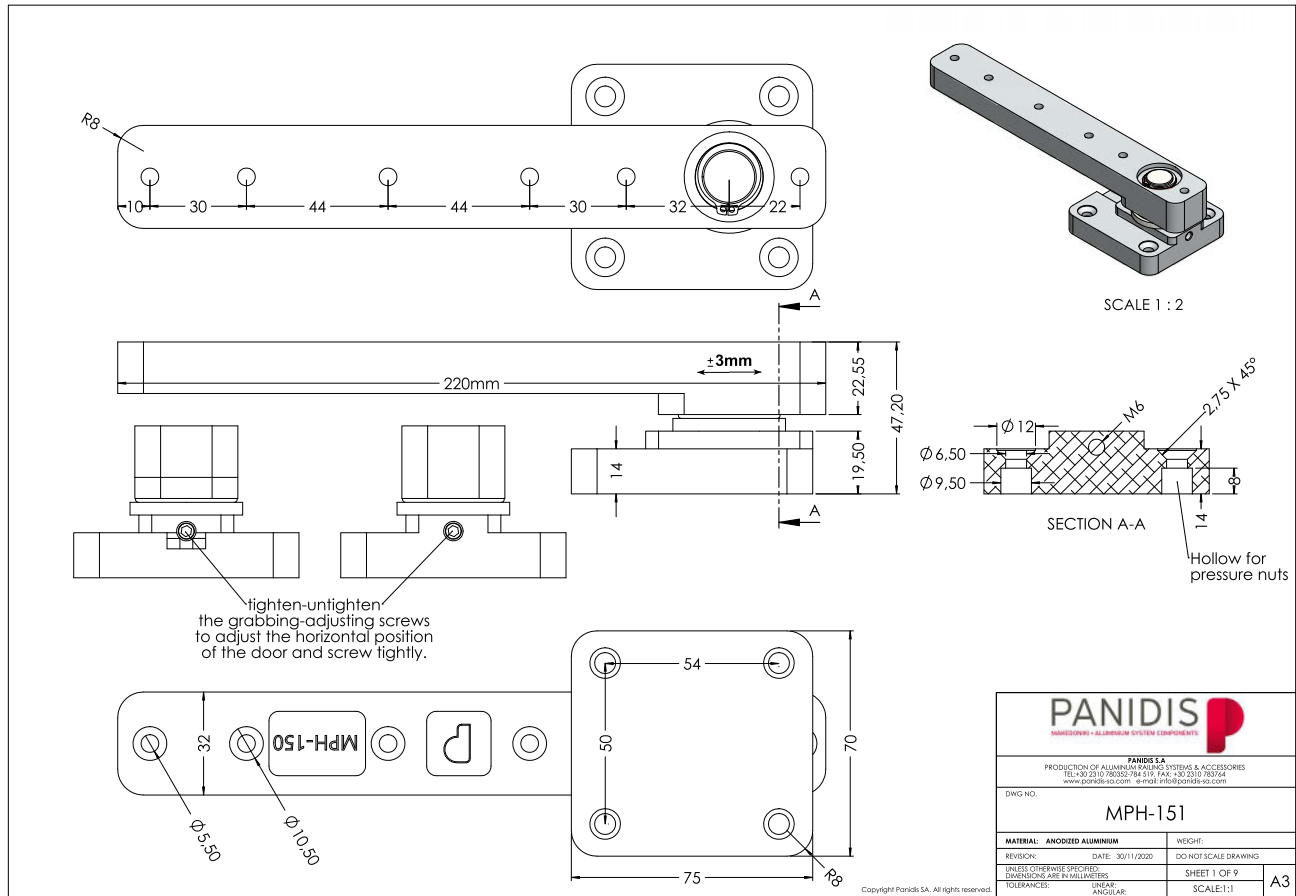

### HINGE PIVOT - MPH-150 Slim Base

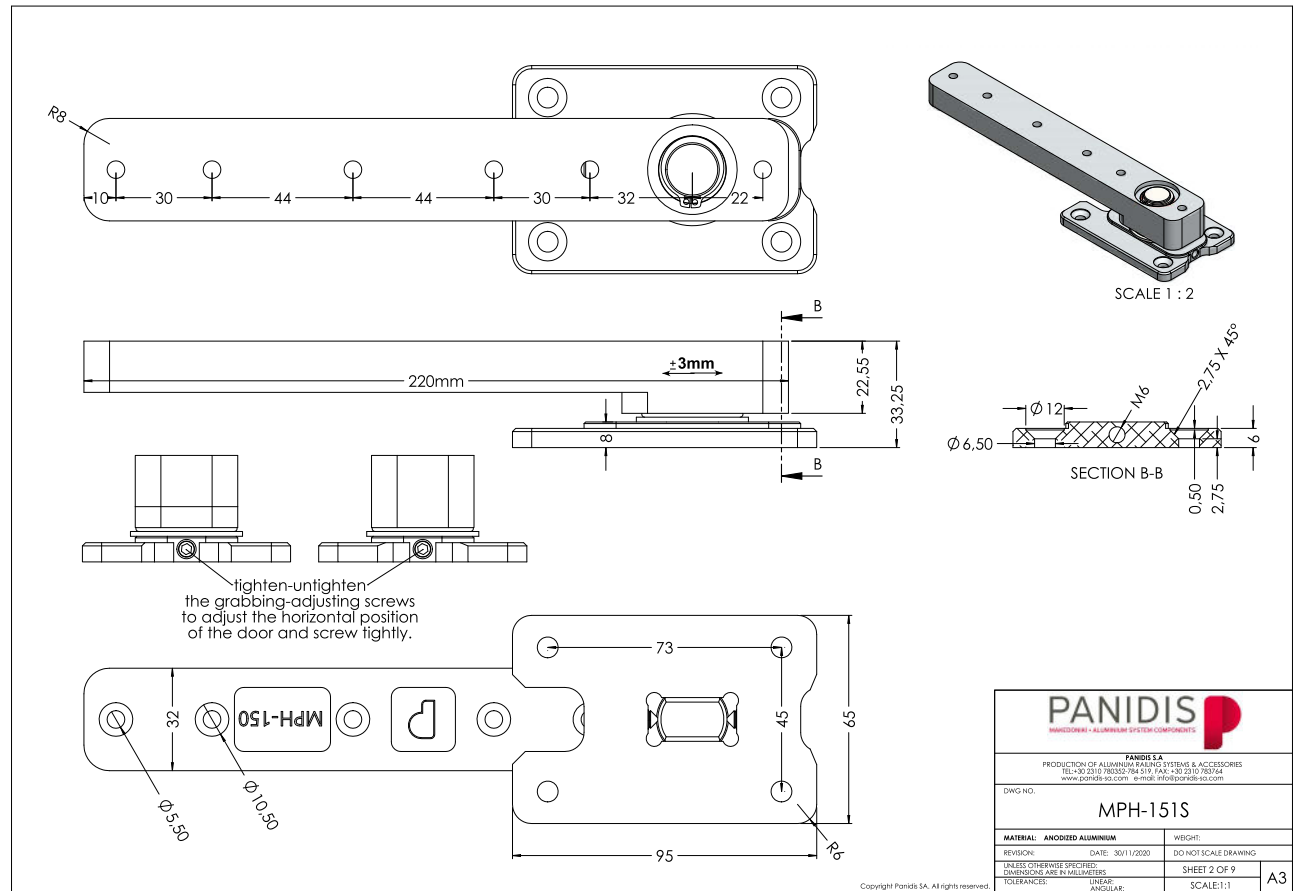

### HINGE PIVOT - MPH-150

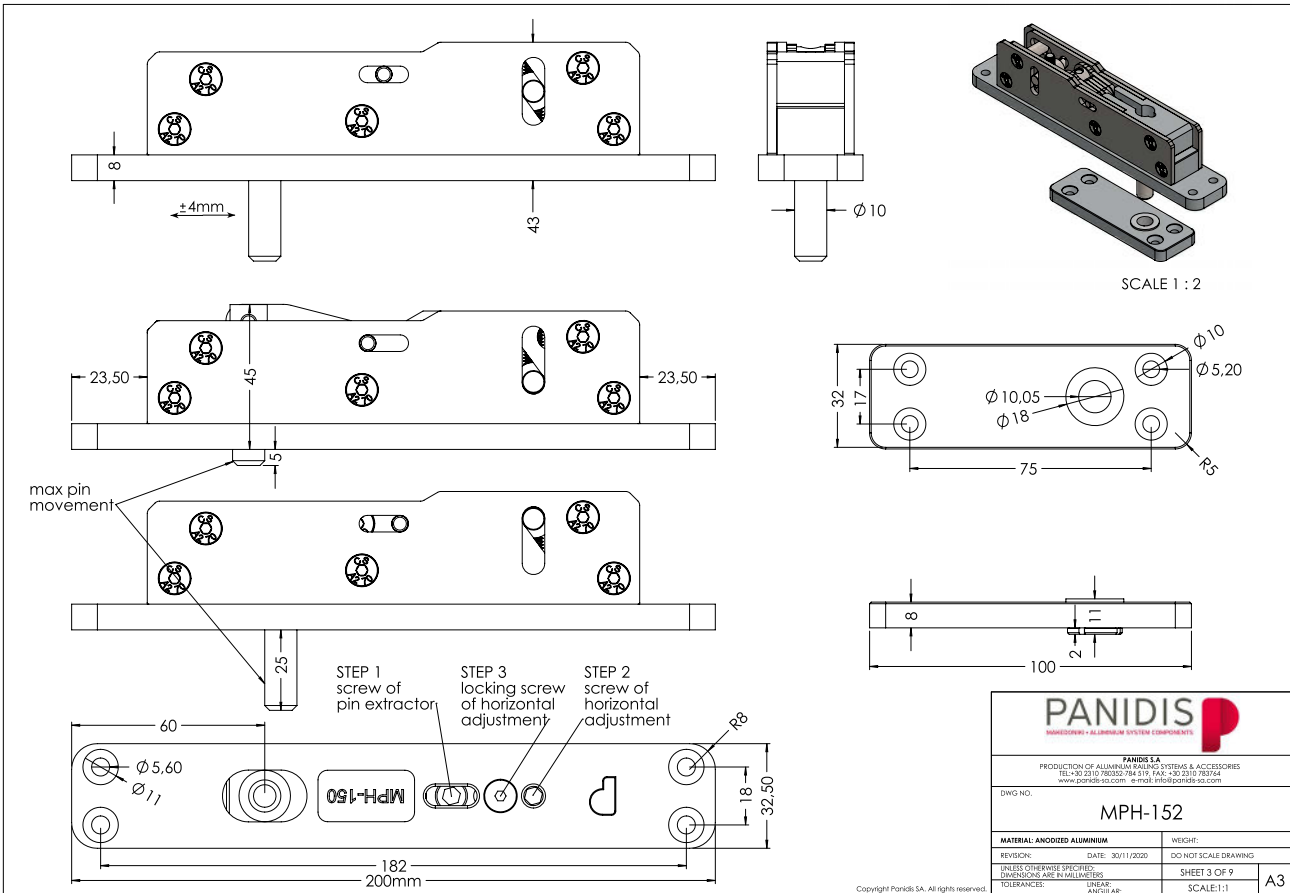

16

### HINGE PIVOT - MPH-150 & MPH-150S

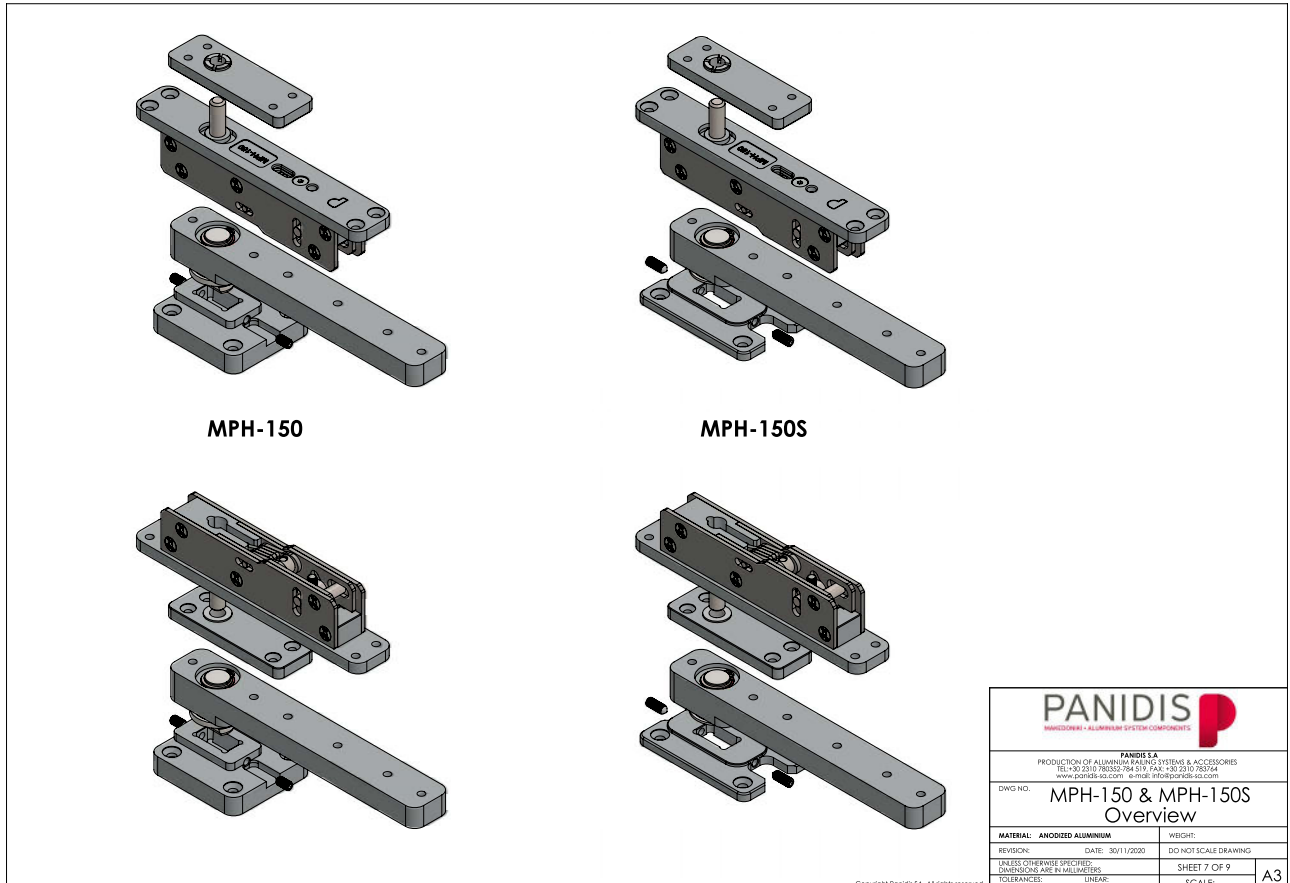

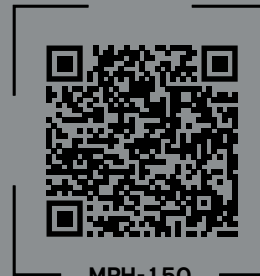

MPH-150  
MPH-150-S

---

**PANIDIS SA**

**Headquarters & Factory**

11th km Old National Road  
Thessaloniki - Kilkis  
P.O. Box 141 • P.C. 570 08  
Ionia • Thessaloniki • Greece  
**T** +30 2310 0 780 352  
+30 2310 784 519  
**F** +30 2310 783 764  
**E** info@panidis-sa.com

**Athens Branch**

38 Chr. Lada & Lisia  
P.C. 121 32  
Peristeri • Athens • Greece  
**T** +30 210 5155 430  
+30 210 5155 439  
**F** +30 210 5155 434  
**E** athina@panidis-sa.com